

REV	DATE	APPROVED	Changes
0	15-09-2015	HBP	

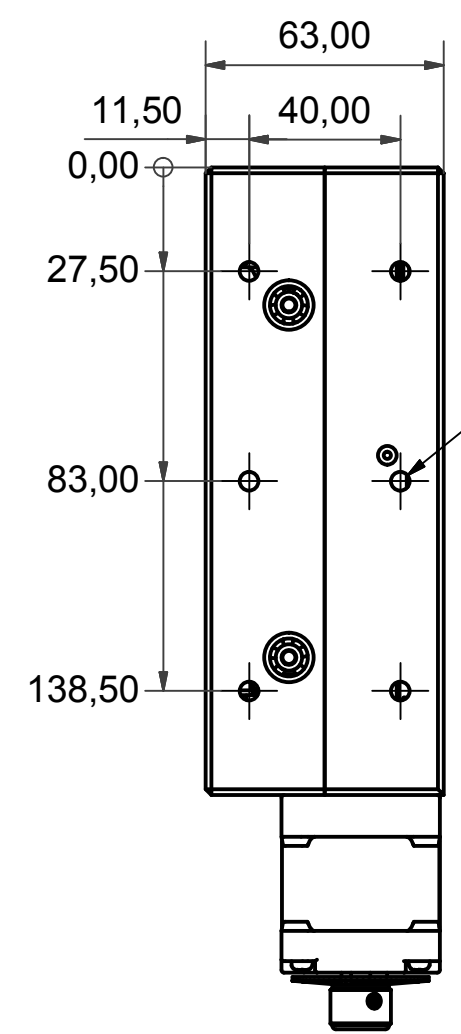

6xM6x1 - 6.0
Holes for mounting.

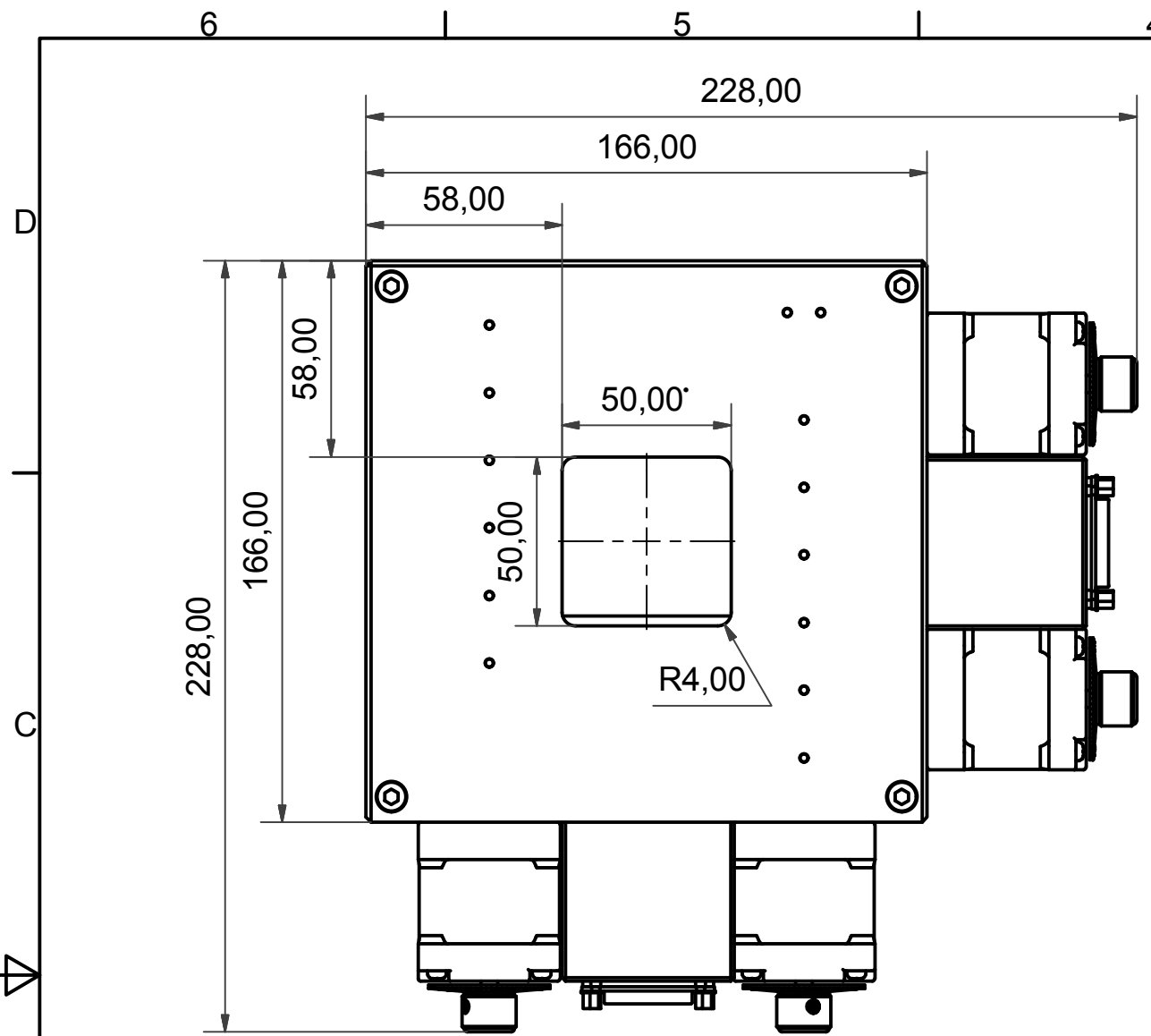
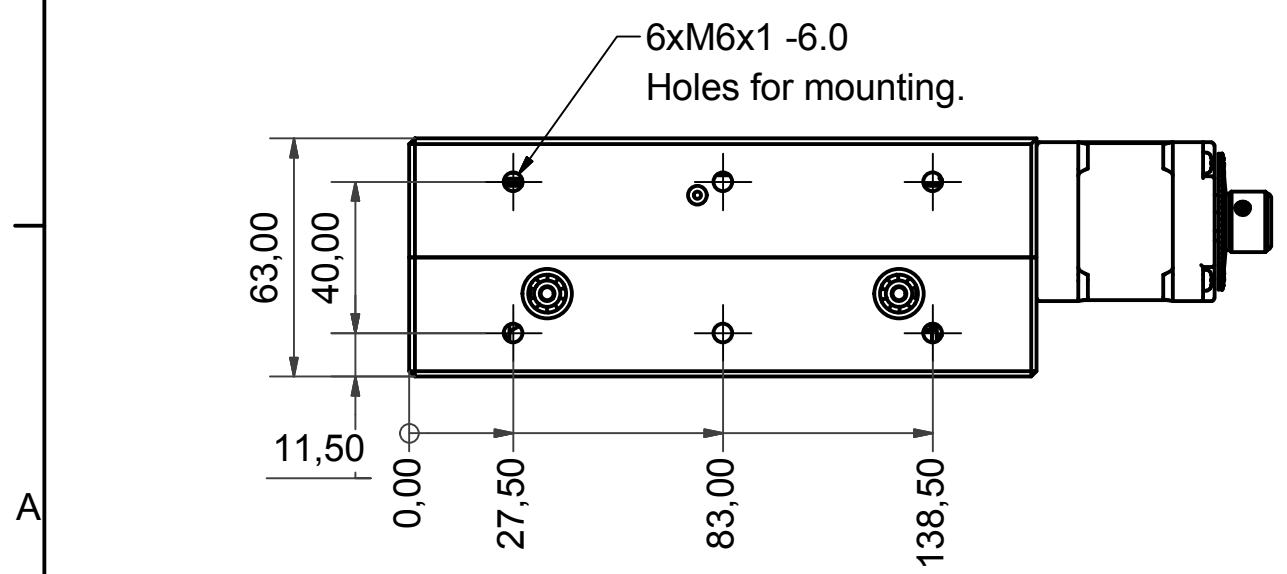
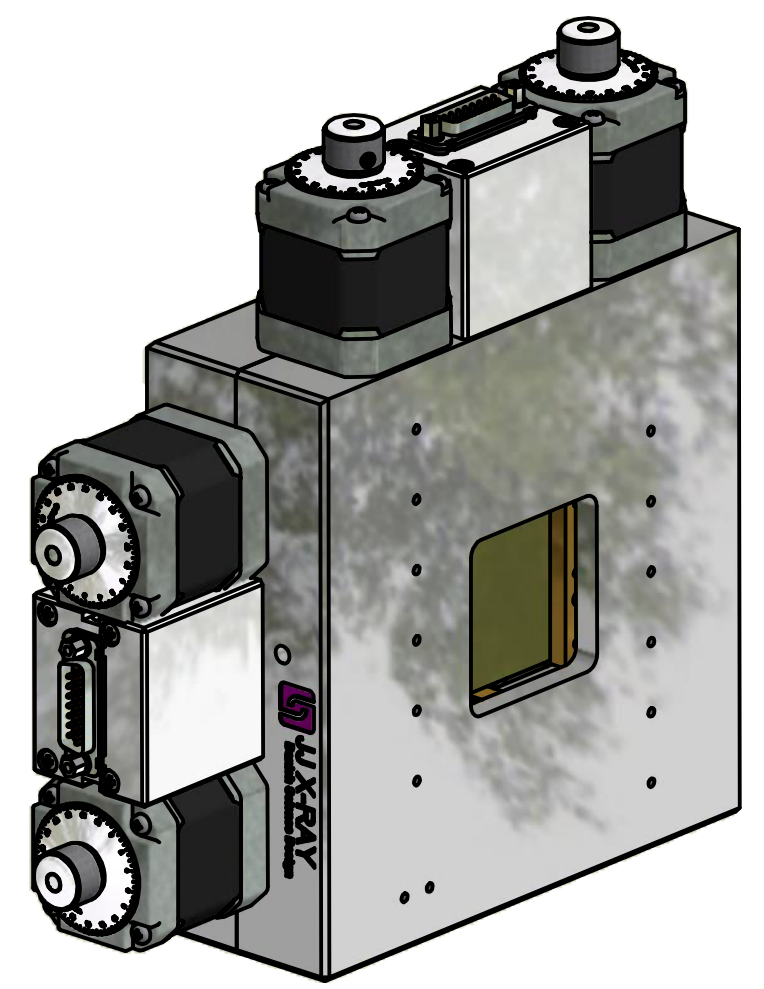

6xM6x1 -6.0
Holes for mounting.

-All dimension are in mm.
-All Tolerances are accordance with ISO 2768-1 class f, unless otherwise specified.
Tolerances:
-Internal corners R0.2 max.
-Break edges 0,1 - 0,25
-√Rz 0,4 max
-Remove all sharp edges and burrs

Date. 14-09-2015	Rev. 0	QTY.
Designer JJ X-Ray A/S	Mass. N/A	
Surface Treatment.		
CAD Drawing Number. IB C50-Air		

Project Name.
JJ X-Ray IB C50-Air slit

Title.
IB C50-Air slit

Remarks.
Scale: 1:1
Drawing Size. A3